

SXC16-5.8

Insulated Metal Panel Attachment

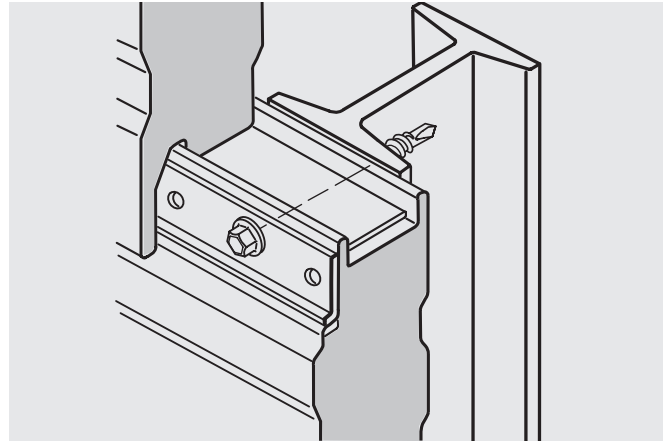
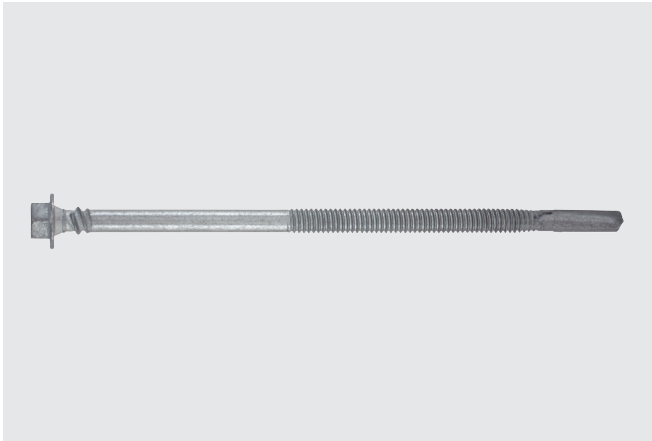

Features and Benefits

- 304 Stainless steel bi-metal provides maximum corrosion resistance while being able to drill steel substrates. 316 Stainless steel is available by request.
- Perfect supporting of the IMP outer-skin given by support thread with cut-off thread-end
- Optimized support function achieved by engineered double support thread
- High performance drill point for heavy steel beams
- High bending capacity for absorption of thermal expansion of the IMP outer-skin
- High tension resistance achieved by optimized fastener geometry

Application

- Insulated metal panel (IMP) to metal beams
- Concealed or face fastened

Features and Benefits continued

- Upgraded major diameter requires less fasteners for the project, and saves installation time due to not needing to pre-drill the application
- Color matched Vista spray available to blend with facade panel

Product Selection

Material No.	Fastener Length		Load Bearing Length		Thread Length		Description	Carton Wt. (lbs.)	Carton Qty.
	(in)	(mm)	(in)	(mm)	(in)	(mm)			
1615954	3-9/16	90	2-3/8	61	2-1/4	58	SXC16-5,8x90-A2	3.5	100
1615960	4-5/16	110	3-3/16	81	2-11/16	68	SXC16-5,8x110-A2	4.2	100
1615963	5-1/8	130	4	101	3-1/16	78	SXC16-5,8x130-A2	4.9	100
1615978	5-15/16	150	4-3/4	121	3-1/16	78	SXC16-5,8x150-A2	5.5	100
1616036	6-11/16	170	5-9/16	141	3-1/16	78	SXC16-5,8x170-A2	6.3	100
1616046	7-7/8	200	6-3/4	171	3-7/16	88	SXC16-5,8x200-A2	7.3	100
1616051	9-1/16	230	7-15/16	201	3-7/16	88	SXC16-5,8x230-A2	8.3	100
1616090	10-1/4	260	9-1/8	231	3-7/16	88	SXC16-5,8x260-A2	9.3	100
1616112	11-13/16	300	10-11/16	271	3-7/16	88	SXC16-5,8x300-A2	10.7	100

Dimensions in inches are approximate conversions.

Note: Fasteners are available with stainless bond seal washer. Inquire with SFS about availability.

SXC16-5.8

Insulated Metal Panel Attachment

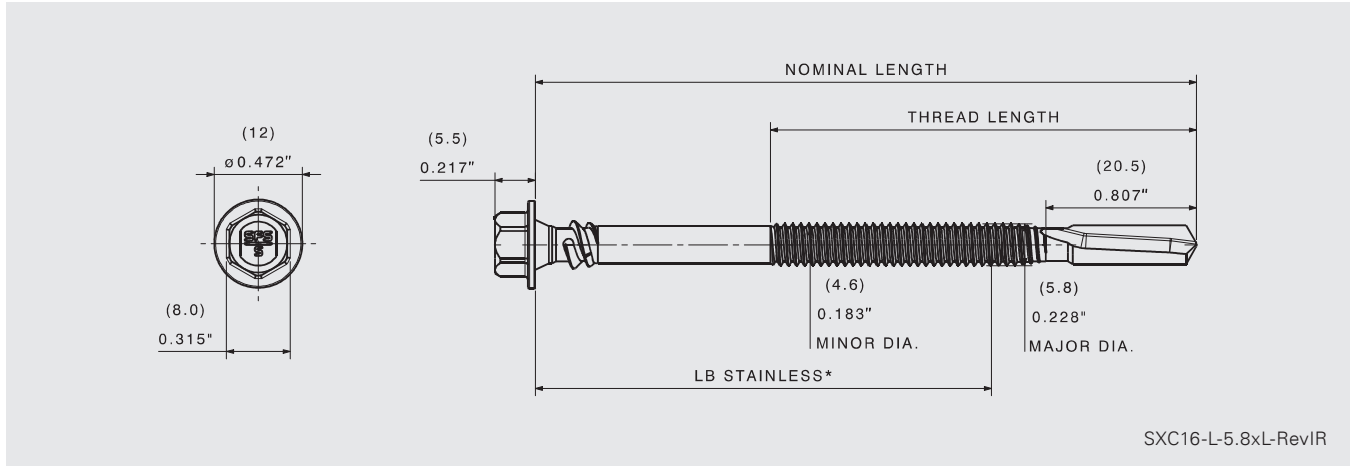

Product Specifications

Diameter: Nominal #12 (5.8 mm)
 Threads Per Inch: 24
 Head Style: 5/16" HWH AF (8.0 mm)
 Material: 304SS

Drill Point: SD5
 Drill Capacity: 0.125"–0.550" (3.2 mm–14.0 mm)
 Thread Major Dia: 0.228" (5.8 mm)
 Thread Minor Dia: 0.183" (4.6 mm)

Performance Data^{1,2}

Material Strength

Tensile	2885 lbf / 12833 N
Shear	2438 lbf / 10845 N
Torsional	128 lbf-in / 14.5 N-m

Pull Out Strength Steel

1/8" (3.2 mm)	2707 lbf / 12041 N
3/16" (4.8 mm)	Exceeds tensile

Pull Over Strength*

26 Ga (0.5 mm):	468 lbf / 2080 N
24 Ga (0.6 mm):	668 lbf / 2970 N

¹ SFS 5890.21

² ETA 13/0183

* with 19 mm washer

Installation and Application Considerations

Fasteners should provide for a minimum of 3 fully developed threads through the metal substrates.

Tools: 0–2000 rpm screw gun equipped with depth sensing nose piece

Use of impact guns or hammer drills is not recommended.