

NVELOPE™

Double Bracket–11 mm slots

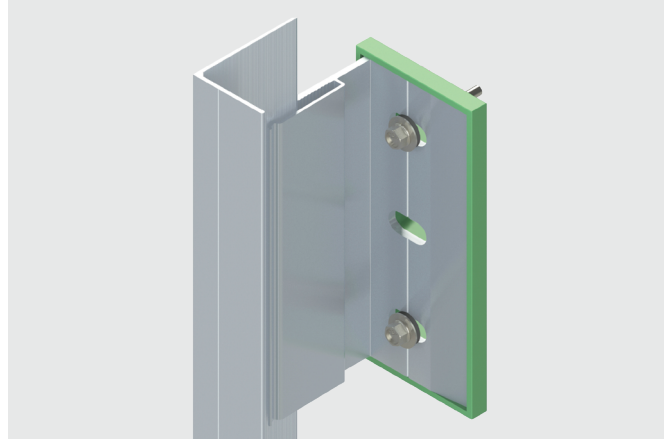
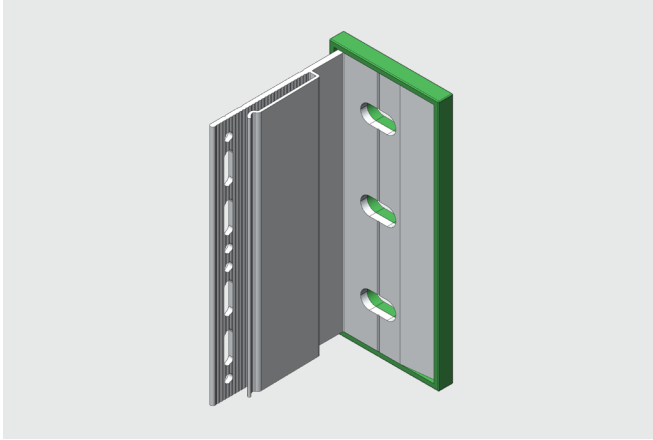

Features and Benefits

- Bracket design allows for rail retainment without additional tools
- Up to 1-½” adjustment range eliminates the need for shims
- Corrosion resistant and 100% recyclable
- Fastener guide marks and integrated thermal isolator to aid in constructability
- Up to a quarter inch of thermal movement
- Engineered to meet thermal code requirements

Application

- Creates a cavity between the architectural cladding and the building for the inclusion of exterior insulation
- Installs directly onto a variety of substrates including steel, wood, concrete and CMU
- Brackets are a component of the NV1 thermally broken subframe system which is used to attach architectural cladding materials utilizing vertically oriented extrusions

Product Selection

Material No.	Bracket Depth (mm)	Cavity Range				Product Code	Carton Wt. (lbs)	Carton Qty.
		Minimum		Maximum				
		(mm)	(in)	(mm)	(in)			
1521238	40	47	1.85	67	2.64	NV-VB40D-11	22	75
1521246	60	62	2.44	102	4.01	NV-VB60D-11	33	75
1521254	90	92	3.62	132	5.19	NV-VB90D-11	33	60
1521262	120	122	4.80	162	6.37	NV-VB120D-11	34	40
1521272	150	152	5.96	192	7.56	NV-VB150D-11	34	35
1521281	180	182	7.16	222	8.74	NV-VB180D-11	34	30
1521290	210	212	8.35	252	9.92	NV-VB210D-11	31	25
1521299	240	242	9.52	282	11.10	NV-VB240D-11	35	25
1521308	270	272	10.70	302	12.28	NV-VB270D-11	33	20
1521316	300	302	11.89	342	13.46	NV-VB300D-11	35	20

NVELOPE™

Double Bracket–11 mm slots

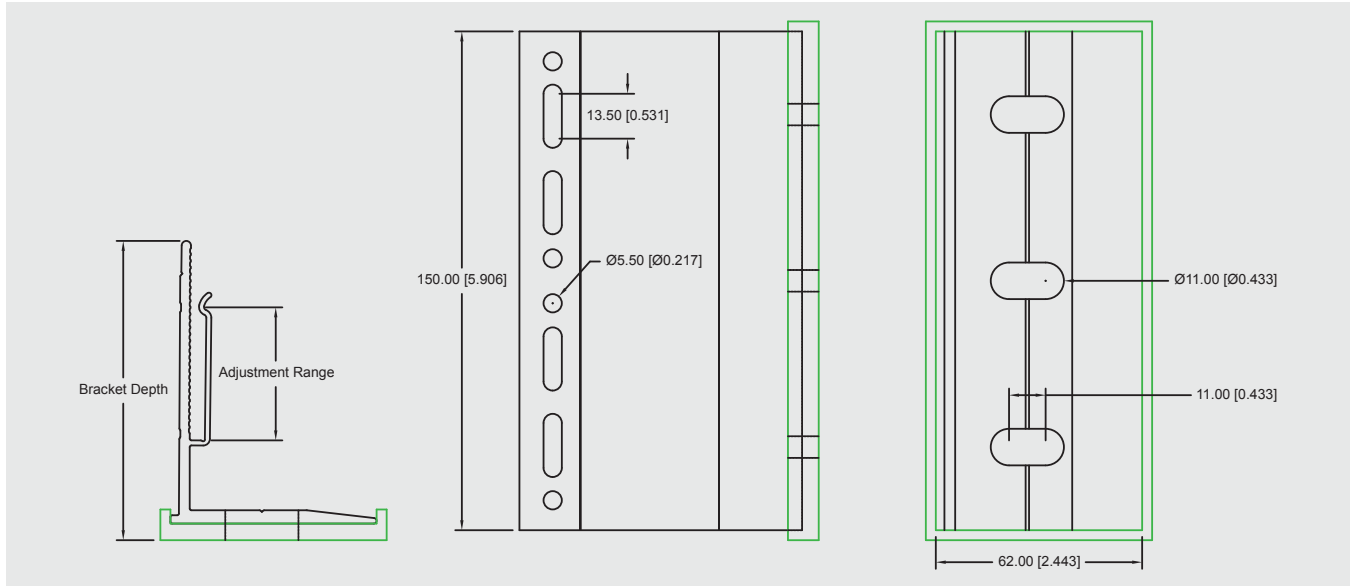

Product Specifications

Bracket Material: 6005A-T6 aluminum
 Isolator Material: Polypropylene
 Isolator Thickness: 5mm

Performance Data^{1,2,3}

Bracket Material Strength

Young's Modulus	10,100 ksi / 70 Gpa
Tensile Strength	38 ksi / 260 Mpa
Shear Strength	24 ksi / 165 Mpa
Tensile Yield	35 ksi / 240 Mpa

Material Thermal Transmittance

Bracket Conductivity:	1339 Btu-in/ft ² -hr-°F (193 W/m-K)
Isolator Conductivity:	0.81 Btu-in/ft ² -hr-°F (0.117 W/m-K)

¹ Inward Horizontal: SFS 1646 / R3

² Outward Horizontal: SFS 5900.21

³ Vertical: SFS 5901.21

Bracket Structural Values

Bracket Size	Vertical Load	Inward Horizontal Load	Outward Horizontal Load
40	1280 lbf / 5.70 KN	1984 lbf / 8.82 KN	1219 lbf / 5.42 KN
60	1150 lbf / 5.12 KN	1455 lbf / 6.47 KN	1338 lbf / 5.95 KN
90	864 lbf / 3.84 KN	1256 lbf / 5.58 KN	1457 lbf / 6.48 KN
120	460 lbf / 2.05 KN	1719 lbf / 7.64 KN	1576 lbf / 7.01 KN
150	405 lbf / 1.80 KN	1234 lbf / 5.49 KN	1695 lbf / 7.54 KN
180	350 lbf / 1.56 KN	903 lbf / 4.02 KN	
210	295 lbf / 1.31 KN	749 lbf / 3.33 KN	
240	240 lbf / 1.07 KN	639 lbf / 2.84 KN	
270	185 lbf / 0.82 KN	573 lbf / 2.54 KN	
300	130 lbf / 0.58 KN	529 lbf / 2.35 KN	