



Metal Building Fastening Solutions



Design, Manufacture & Supply

SFS is the building envelope specialist. We serve the construction industry with fastening solutions for low slope roofing, post-frame construction, metal building systems, commercial construction facades and curtain walls, subframe support systems, offsite and modular construction and mass timber construction.

But we're not just a fastener company. We have designed and developed innovative installation tools that increase productivity and make installation more accurate and easier.

At SFS, our vertically integrated supply chain keeps the fastener production, coating and packaging of our products in our hands. This provides greater assurance that we will live up to our quality, delivery and service commitments.

Together with our expertise, we can help you find the right product and systems for your project.

Table of Contents

Impax™ Self-drill	7
Impax™ Sealer Self-drill	8
Impax™ 410 Stainless	8
ZAC® Impax™ Self-drill and Tapping	8
MAC™ Impax™ Self-drill	9
Self-tapping	10
Flex5 Grade 5	10
Bi-Met 300®	11
BULB-TITE® Rivets	11

Intense Color, Ultimate Performance

Our VistaCoat® premium system is a proprietary high-performance finish that is durable, provides exceptional UV and corrosion resistance and is environmentally friendly. This system is designed to endure rigorous fastener applications and provide the highest quality installed product.

SFS has the ability to color match to any panel color, but we've already made it easy by offering a broad pallet of standard colors that match the majority of OEM panels. Check out our online color selector tool – its easy to find the SFS color code to match many OEM panel colors.

If you are a panel manufacturer and want fasteners perfectly matched to your panels, just submit a color chip to us.

SFS Standard VistaCoat® colors

The below chart is a representation of our standard VistaCoat® color offering. Color swatches are a representation only, and not to be used for exact matching.

White

- 014 Bright White
- 001 White
- 348 Bone White
- 330 Warm White
- 818 Sierra White

Brown

- 020 Tan
- 548 Ivory
- 248 Light Stone
- 415 Beige
- 109 Sand Beige
- 422 Taupe
- 230 Desert Brown
- 110 Brown
- 374 Dark Brown

Green

- 385 Patina
- 052 Teal Green
- 660 Hemlock
- 232 Evergreen
- 732 Denali Green
- 228 Green
- 925 Classic Green
- 798 Hartford Green

Red

- 102 Crimson Red
- 928 Terra Cotta
- 890 Red
- 691 Barn Red
- 074 Colonial Red
- 393 Burgundy

Bronze

- 537 Medium Bronze
- 042 Burnished Slate
- 324 Dark Bronze

Blue

- 432 Blue Teal
- 012 Blue
- 843 Regal Blue
- 421 Navy

Black

- 023 Black
- 507 Matte Black

Gray

- 850 Ash Gray
- 302 Pearl Gray
- 578 Old Town Gray
- 696 Pewter Gray
- 091 Zinc Gray
- 051 Charcoal Gray
- 416 Slate Gray

Metallic

- 1160 Champagne Metallic
- 1161 Silver Metallic
- 1162 Zactique Metallic
- 1116 Copper Penny Metallic



We're Committed to Service

At SFS, positive customer experience is paramount. We are committed to fulfilling customer requirements by going above and beyond expectations. We blend proactive engineering and holistic add-on services to provide our customers end to end solutions.

Our services at a glance

Engineering services

Our highly creative technical specialists provide a systematic approach. This includes multi-disciplined engineering services which ensure optimal performance of the building envelope.

Services for facade framing systems

We are experts in design development, shop drawings and submittal calculations on complex building facades.

Order and delivery services

Our reliable order processes and worldwide delivery network, ensure complete and on-time as ordered service.

Job site services

Our professional network offers on-site product training.

Tool repair program

We offer quick turn-around repair service of SFS productivity tools.

eLogistics

Our automated logistics processes with track and trace features mean customers spend less time from order to delivery.



Our Online Power Tools



SFS connects you to the information you need with powerful, online tools. Easy to use, these tools take the guess work out of the equation. You can feel confident when you place an order that you will receive exactly what you need.

NVELOPE budget calculator

Quickly and easily estimates the square foot cost of NVELOPE thermally broken cladding support system materials needed for your project.

NVELOPE DesignRX

Design a rainscreen bracket system dependent on factors such as local wind loads, height of the facade, substrate being fixed to, selected cladding material and the cladding zone. All NVELOPE cladding systems can be engineered to project specific requirements.

Fastener color selector

Makes finding the perfect SFS color match to an OEM panel easy.

Panel clip product finder

Provides all the SFS standing seam roof panel clips that work with your roll forming equipment and attachment method.

VistaVent® ridge ventilation product finder

Identifies the SFS product which is cut to fit your panel profile.

VistaFoam® closure product finder

Three easy ways to find closure cut to fit your panel profile.

Require more information?

This brochure is just an overview of the many products and services SFS has to offer. You may find you need more information before you are ready to buy... and SFS has it available for you. Always feel free to contact us by phone or email. Or visit our website where you can easily find a vast array of information at your fingertips.

Product data sheets

We have indepth product data sheets available on most products published on our website for easy viewing or download. These data sheets provide information on:

- Application
- Features and benefits
- Product specifications
- Engineering drawing
- Performance values
- Product selection
- Installation and application considerations

SFS

#12-14 ZAC® Impax SD3 (5/16") Metal to Metal Fastener



Features and Benefits

- Zinc alloy cast-head that will never rust
- Precision cold forged assuring superior strength and the fastest driving time performance
- Designed to have low driving and thread engagement torque and provide maximum clamping load
- Special long pilot length to accommodate rusted surfaces
- Assisted EPDM seating washer for a consistent weather tight seal
- Long life fastener limited warranty

Application
Manufactured for light and medium gauge metal application.

Product Selection

Material No.	Fastener Length	Thread Length*	Description
794238	1"	Full	ZS24-#12
1024876	1-1/4"	Full	ZS24-#12
1025181	1-1/2"	Full	ZS24-#12
798548	2"	Full	ZS24-#12

*Plain product bagged 250 pieces, unless otherwise noted.
*Note - Thread length measured from end of pilot length to end of the thread.

US: T 800 234 4533 | Canada: T 866 847 5400 | www.sfsintecusa.com | www.sfsintec.ca

Ready to buy?

We're here to assist you in your purchase decision and make it easy. Our SFS outside sales force and our inside customer service team are available to answer questions and make your journey a smooth one.

United States

800 234 4533
T +1 610 376 5751
us.construction@sfsintec.biz
www.sfsintecusa.com

Canada

866 847 5400
T +1 905 689 5401
ca.info@sfsintec.biz
www.sfsintec.ca

SFS

#12-14 ZAC® Impax SD3 (5/16") Metal to Metal Fastener

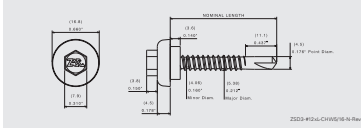

Product Specifications

Diameter: #12 (5.38 mm)
 Threads Per Inch: 14
 Head Style: 5/16" dia Zinc alloy capped HVH AF
 (7.9 mm)

Washer: EPDM seating washer
 Drill Point: SD3
 Drill Capacity: 0.550"-0.210" (13.889 mm-5.334 mm)
 Thread Major Dia: 0.212" (5.38 mm)
 Thread Minor Dia: 0.162" (4.06 mm)

Performance Data**

Material Strength	Pull Out Strength Steel	ICC-pretreated 45 ksi		SFS testing 55 ksi	
		Steel	Concrete	Steel	Concrete
2500 SF / 11125 N	16 dia (13 mm)	481 SF / 2142 N	481 SF / 2142 N	481 SF / 2142 N	481 SF / 2142 N
1950 SF / 8707 N	14 dia (11 mm)	315 SF / 1405 N	315 SF / 1405 N	315 SF / 1405 N	315 SF / 1405 N
1520 SF / 6760 N	12 dia (9 mm)	224 SF / 1002 N	224 SF / 1002 N	224 SF / 1002 N	224 SF / 1002 N

Pull Out Strength Steel

28 dia (22 mm)	854 SF / 3793 N
24 dia (19 mm)	750 SF / 3347 N
22 dia (18 mm)	523 SF / 2334 N

*SFS 2024-14-020 (11)
*SFS 2024-14-020 (11)
*SFS 2024-14-020 (11)
*SFS 2024-14-020 (11)

Installation and Application Considerations

Tools: 5-2000 rpm screw gun equipped with depth sensing nose piece. Fastener length should provide for a minimum of 3/16" penetration of fully developed threads into metal substrate.







Use of impact guns or hammer drills is not recommended.

Notes: Values are approximate values. The steel used in tests of tensile strength and threadline are non-binding and do not represent a guarantee. Values are for full thread penetration. All conditions described herein are subject to change without notice. The user is responsible for determining the use and application of the product.

US: T 800 234 4533 | Canada: T 866 847 5400 | www.sfsintecusa.com | www.sfsintec.ca

Metal Building Fastening Solutions



Impax™ self-drill

	Product	Diameter	Threads per inch	Head style/drive	Washer*	Point	Lengths
	#12-14 Impax SD3	#12	14	5/16" HWH	Bond seal	SD3	3/4" to 4"
	1/4-14 Impax Lap	1/4"	14	5/16" HWH	Bond seal	SD1	7/8"
	1/4-14 Impax SD2	1/4"	14	5/16" HWH	Bond seal	SD2	1-1/4" to 1-1/2"
	1/4-14 Impax SD2	1/4"	14	3/8" HWH	Bond seal	SD2	1"
	1/4-14 Impax SD3	1/4"	14	3/8" HWH	Bond seal	SD3	3/4" to 4"
	#12-24 Impax SD4.5	#12	24	5/16" HWH	Bond seal	SD4.5	1-1/4"
	#12-24 Impax SD5	#12	24	5/16" HWH	Bond seal	SD5	1-1/4" to 2"
	1/4-20 Impax SD5	1/4"	20	3/8" HWH	Bond seal	SD5	3" to 8"
	#10-16 Impax Utility SD3	#10	16	5/16" HWH	Bond seal	SD3	3/4" to 1-1/2"
	#8-18 Impax Utility SD2	#8	18	1/4" HWH	Bond seal	SD2	1/2" to 3/4"



*Available without washer.

Metal Building Fastening Solutions

Impax™ sealer self-drill

	Product	Diameter	Threads per inch	Head style/drive	Washer	Point	Lengths
	12-14 Impax sealer SD3	#12	14	5/16" cupped HWH	EPDM sealer	SD3	3/4" to 1-1/2"
	1/4-14 Impax sealer lap	1/4"	14	5/16" cupped HWH	EPDM sealer	SD1	7/8"



Impax™ 410 Stainless

	Product	Diameter	Threads per inch	Head style/drive	Washer*	Point	Lengths
	#12-14 410SS SD3	#12	14	5/16" HWH	Aluminum bond seal	SD3	1 to 1-1/2"
	1/4-14 410SS Lap	1/4"	14	5/16" HWH	Aluminum bond seal	SD1	7/8"

*Available without washer.

ZAC® Impax™ self-drill and tapping

Zinc alloy cap that will never red rust

	Product	Diameter	Threads per inch	Head style/drive	Washer	Point	Lengths
	#12-14 ZAC® SD3	#12	14	3/8" HWH zinc alloy capped	EPDM sealer	SD3	1" to 3"
		#12	14	5/16" HWH zinc alloy capped	EPDM sealer	SD3	1" to 2"
	#1/4-14 ZAC® Lap	1/4"	14	3/8" HWH zinc alloy capped	EPDM sealer	SD1	7/8"
		1/4"	14	5/16" HWH zinc alloy capped	EPDM sealer	SD1	7/8"

Metal Building Fastening Solutions



ZAC® Impax™ self-drill and tapping continued

Zinc alloy cap that will never red rust

	Product	Diameter	Threads per inch	Head style/drive	Washer	Point	Lengths
	#1/4-14 ZAC®	1/4"	14	3/8" HWH zinc alloy capped	EPDM sealer	SD2	1-1/4" to 1-1/2"
		1/4"	14	5/16" HWH zinc alloy capped	EPDM sealer	SD3	1-1/4"
	#12-24 ZAC®	#12	24	3/8" HWH zinc alloy capped	EPDM sealer	SD4.5	1-1/4"
		#12	24	3/8" HWH zinc alloy capped	EPDM sealer	SD5	1-1/4" to 1-1/2"
	1/4-14 ZAC® AB	1/4"	14	3/8" HWH zinc alloy capped	EPDM sealer	Type AB milled point	1" to 2-1/2"
	#17 ZAC® AB	#17	14	3/8" zinc alloy capped	EPDM sealer	Type AB	1" to 1-1/2"

MAC™ Impax™ Self-drill



304 stainless capped head

	Product	Diameter	Threads per inch	Head style/drive	Washer	Point	Lengths
	12-14 MAC SD3	#12	14	5/16" HWH stainless capped	EPDM sealer	SD3	1" to 1-1/2"
	1/4-14 MAC Lap	#12	14	5/16" HWH stainless capped	EPDM sealer	SD1	7/8"

Metal Building Fastening Solutions

Self-tapping



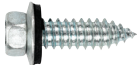

Available in carbon steel or 304 stainless steel

	Product	Diameter	Threads per inch	Head style/drive	Washer*	Point	Lengths
	#14 Type A	#14	10	3/8" HH	Bond seal	Type A	CS 3/4" to 6" SS 3/4" to 8"
	1/4-14 Type B	1/4"	14	3/8" HH	Bond seal	Type B	CS 3/4" to 6" SS 3/4" to 8"
	1/4-14 Type AB	1/4"	14	3/8" HH	Bond seal	Type AB	CS 3/4" to 1-1/2" SS 3/4" to 1-1/2"
	#17 Type AB	#17	14	3/8" HH	Bond seal	Type AB	CS 3/4" to 1-1/2" SS 3/4" to 1-1/2"

*Available without washer.

Flex5 Grade 5



Selectively hardened alloy steel with Grade 5 performance

	Product	Diameter	Threads per inch	Head style/drive	Washer	Point	Lengths
	10-16 Flex5 SD3	#10	16	5/16" HWH	-	SD3	3/4"
	12-14 Flex5 SD3	#12	14	5/16" HWH	-	SD3	7/8" to 2"
	1/4-14 Flex5 SD3	1/4"	14	3/8" HWH	-	SD3	1" to 2"
	1/4-20 Flex5 SD4	1/4"	20	3/8" HWH	-	SD4	1-1/8" to 2-1/2"



Metal Building Fastening Solutions

Bi-Met 300®

304 stainless fastener with carbon steel point

	Product	Diameter	Threads per inch	Head style/drive	Washer	Point	Lengths
	1/4-14 Bi-Met 300 SD2	1/4"	14	3/8" HWH	-	SD2	1" to 2"
	1/4-20 Bi-Met 300 SD4	1/4"	20	3/8" HWH	-	SD4	1-1/8" to 2"
	1/4-20 Bi-Met 300 SD5	1/4"	20	3/8" HWH	-	SD5	2" to 4"

BULB-TITE® Rivets

	Product	Body	Head style/drill point	Substrate
	9/32" BULB-TITE® Rivet	Aluminum body and mandrel	Dome head or large flange head	Steel or aluminum
	3/16" BULB-TITE® Rivet	Aluminum body and mandrel	Dome head	Steel or aluminum



SFS Group USA, Inc.
Division Construction
1045 Spring Street
US-Wyomissing, PA 19610

800 234 4533
T +1 610 376 5751
F +1 610 376 8551
us.construction@sfsintec.biz
www.sfsintecusa.com

SFS – Canada
40 Innovation Drive
Dundas, ON L9H 7P3

866 847 5400
T +1 905 689 5401
ca.info@sfsintec.biz
www.sfsintec.ca