

American Standard Blind Rivet

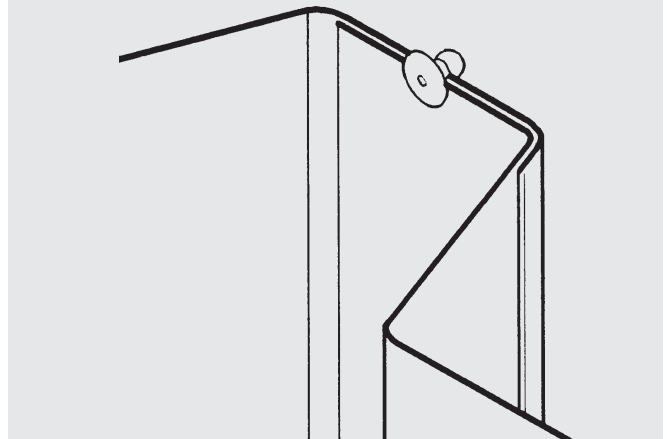
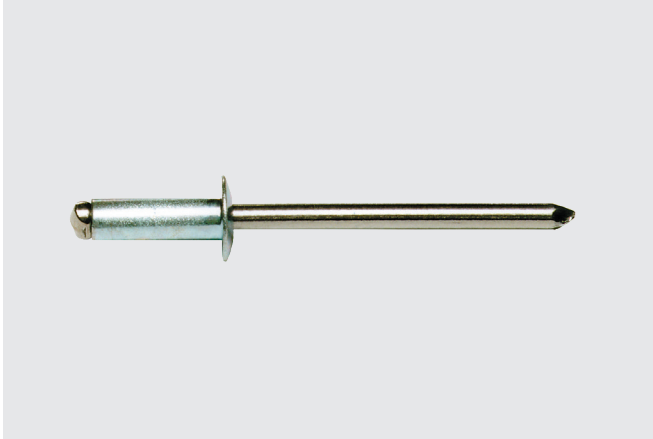

Features and Benefits

- 1/8" dome head style
- Provides secure and permanent fastening solution
- Good installed appearance
- Won't loosen in high vibration or fatigue applications
- Quality and repeatability of assembly
- No over driving or under driving
- Installed function of the rivet will be consistent and is independent of the installer's technique

Application

Metal trim applications and other light gauge installations

Product Selection

Material No.	Rivet Diameter	US Dimension	Description	Grip Range
792376	1/8"	43	STST43D rivet	0.126"–0.187"
1657138	1/8"	44	STST44D rivet	0.188"–0.250"
1657144	1/8"	46	STST46D rivet	0.251"–0.375"
1243078	1/8"	48	STST48D rivet	0.376"–0.500"

Rivets available painted to match standard industry colors.

Rivet material: body 304SS; mandrel 302SS

Other sizes available upon request

American Standard Blind Rivet

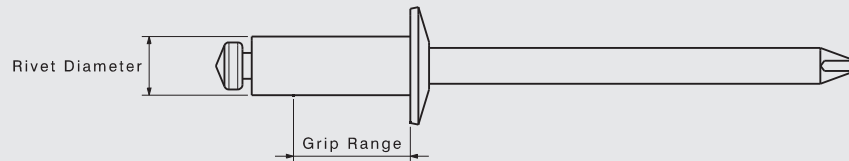

STST43D-RevIR

Installation and Application Considerations

Use of a #30 drill bit is required for a pre-drill hole size of 0.129"–0.133" (3 mm–3.3 mm).